

## F20 Stair to Multi-ply BCI® Joist header.

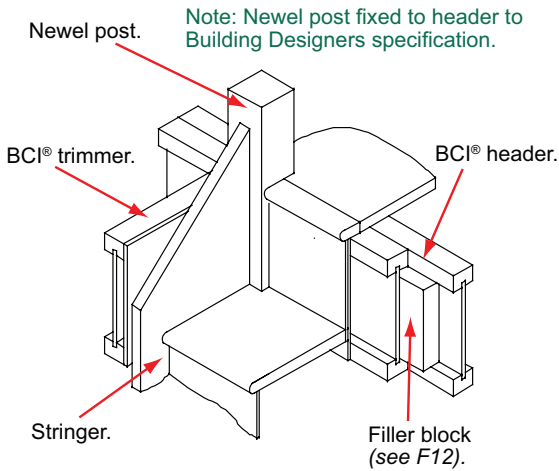

## F20a Stair to VERSA-LAM® header.

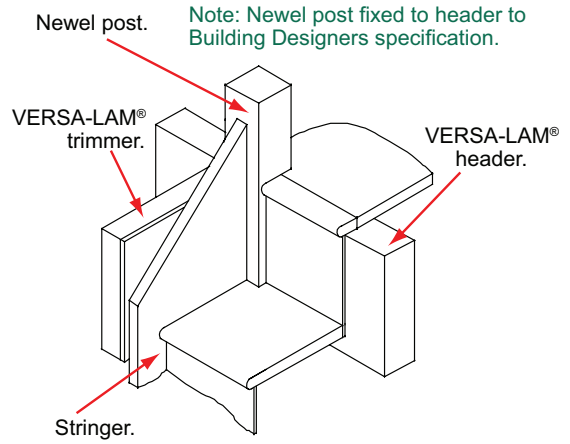

## F20b Stair to BCI® Joist header.

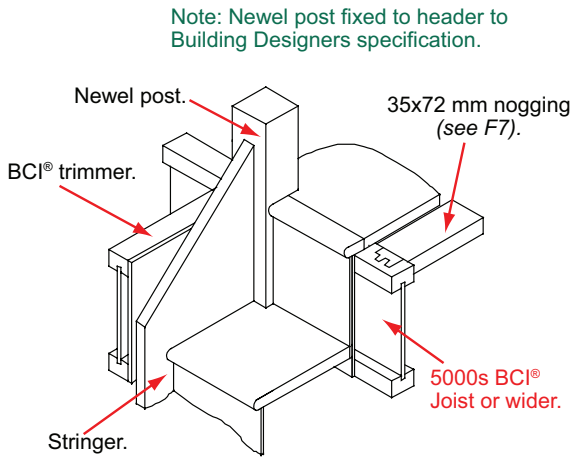

## F21 Masonry support for VERSA-LAM® beams.

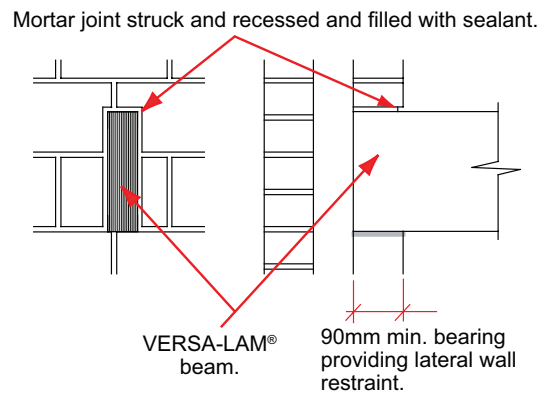

## F22 Hoist to BCI® Joist fixing.

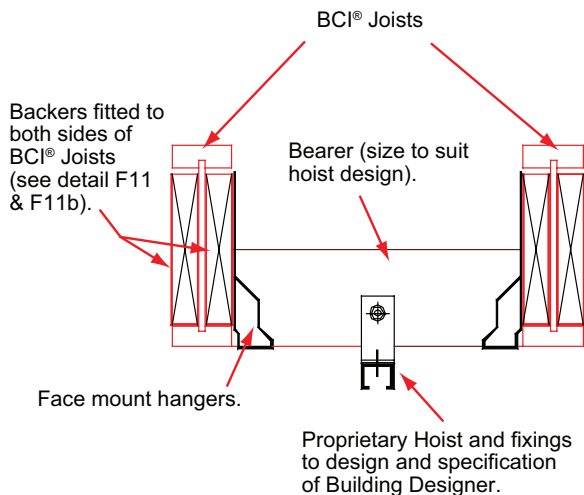

## F23 Temporary platform at stairwell.

