

F18a Lateral restraint for masonry (strap through 241mm BCI® Joist).

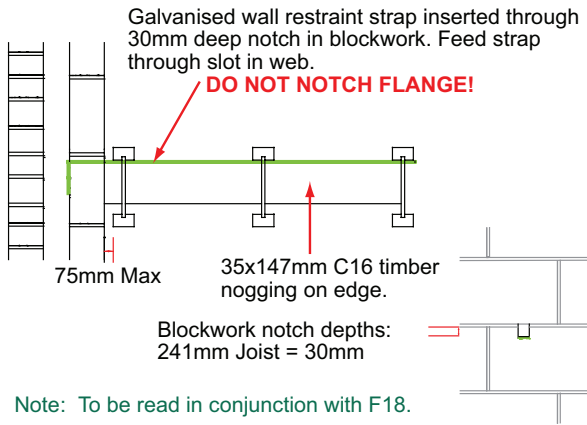

F18b Lateral restraint for masonry (strap through 302mm or deeper BCI® Joist).

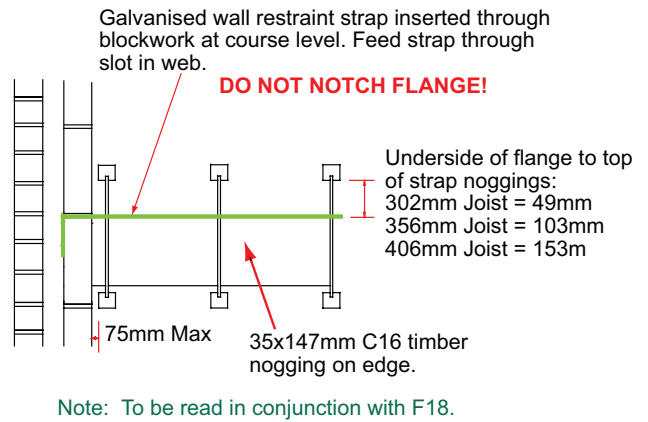

F18c Lateral restraint for masonry (perpendicular strap over BCI® Joist).

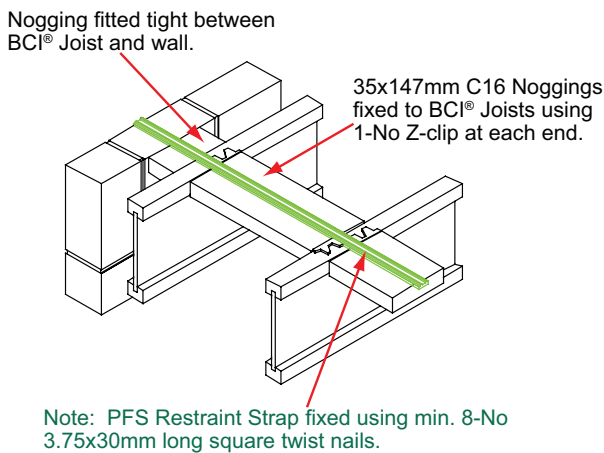

F18d Lateral restraint for masonry (strap to side of hanger supported BCI® Joist).

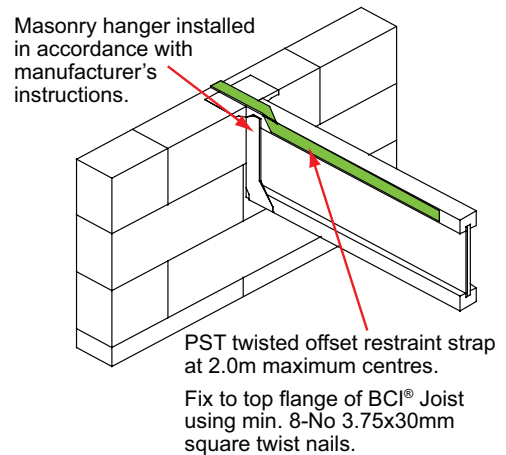

F18e Lateral restraint for masonry (Simpson Strong-Tie Safety Fast Hanger).

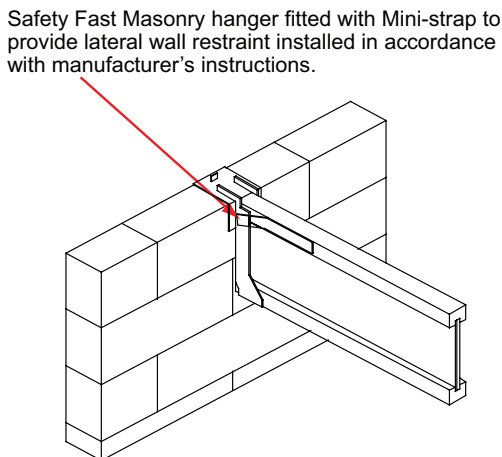

F19 Continuous BCI® Joist through masonry wall.

