

F17

Boise I-Bloc™.

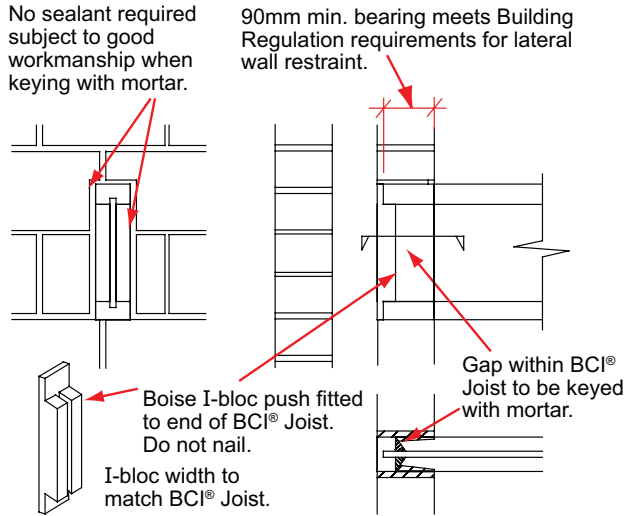

F17a

Plywood packer and silicone sealant.

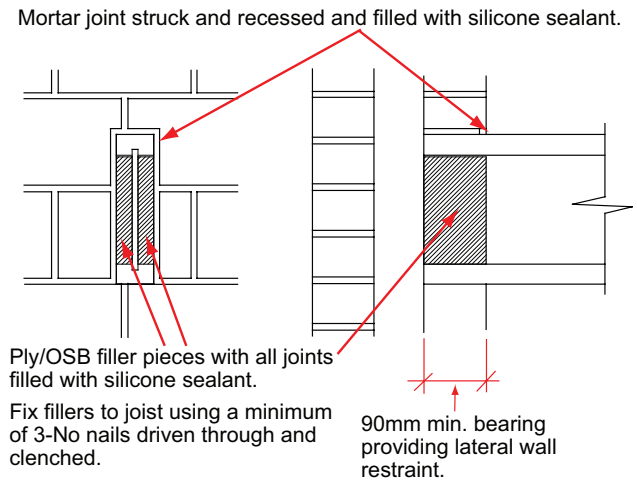

F17b

Cullen Restraint Angle.

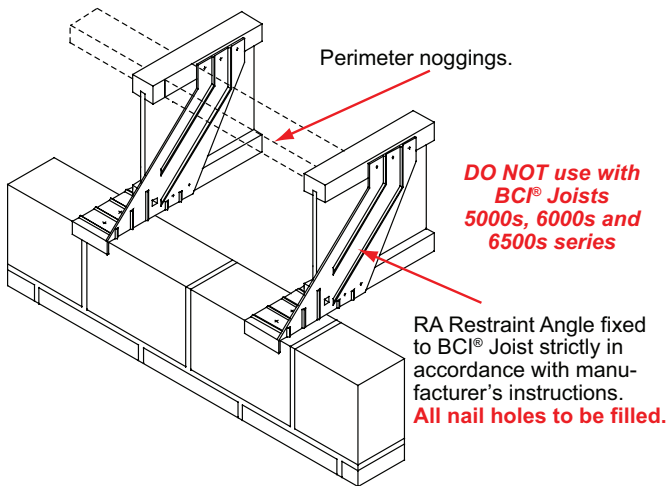

F17d

Plastic Joist Box.

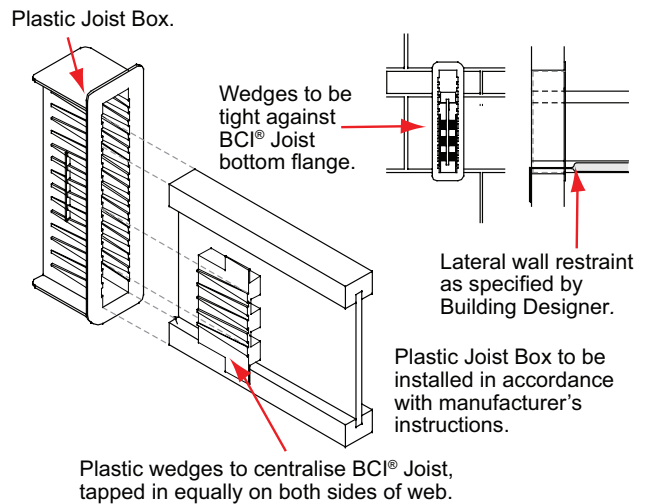

F17e

Ledger beam fixed to masonry.

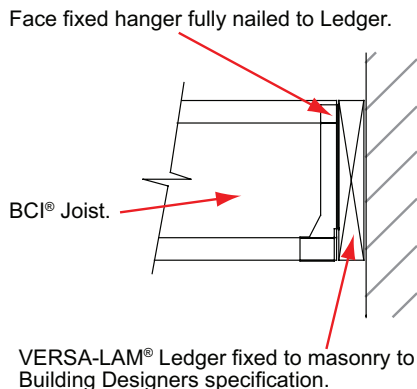

F18

Lateral restraint for masonry (strap through BCI® Joist).

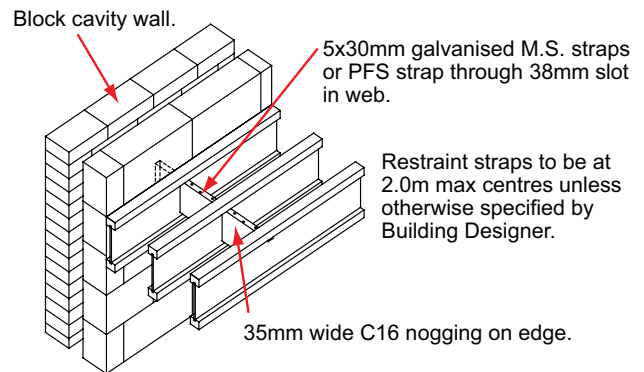

Note: Fix using min. 3-No 3.75x30mm square twist nails.